

## 2831GE SCU



Descrizione di riferimento vedi Art. 2831GA

Tipo orizzontale, base piana.

Forza max .....	daN	100	170	300
Ø vite filettata .....	M	6	8	10
Misura puntale esag. ....	mm	10	13	16
Peso .....	grammi	110	220	500
<b>2831GE</b>	<b>Cad.</b>	<b>38,30</b>	<b>44,60</b>	<b>67,20</b>

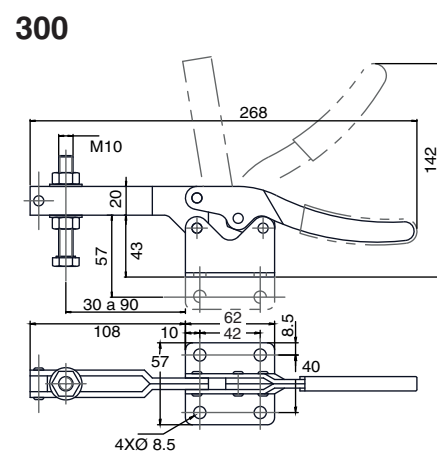
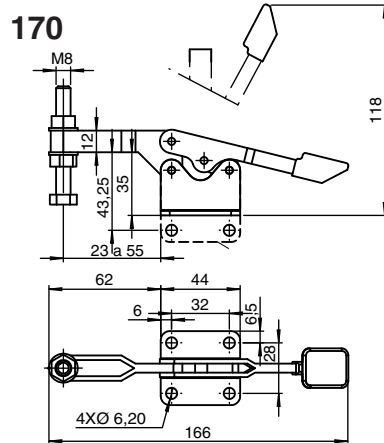
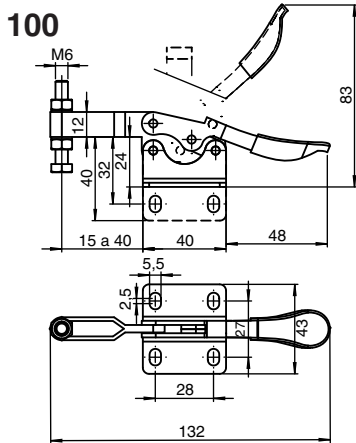

## 2831GL SCU



Descrizione di riferimento vedi Art. 2831GA

Tipo a spinta e trazione, base piana.

Forza max .....	daN	200	1200	2000
Ø vite filettata .....	M	8	10	12
Misura puntale esag. ....	mm	13	16	18
Peso .....	grammi	400	650	1500
<b>2831GL</b>	<b>Cad.</b>	<b>78,40</b>	<b>140,00</b>	<b>184,00</b>

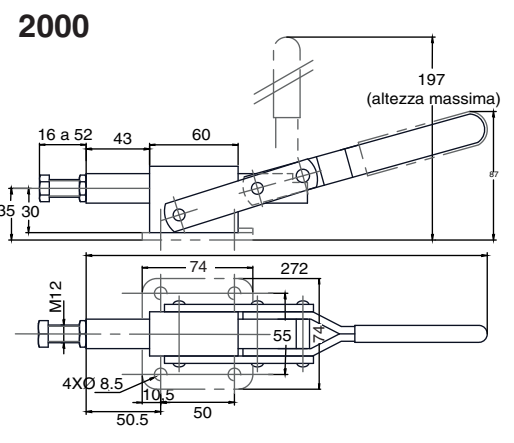
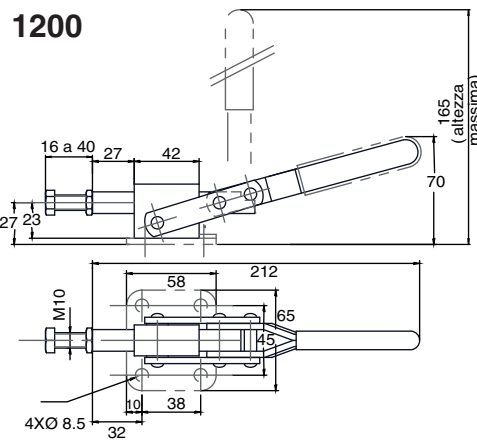
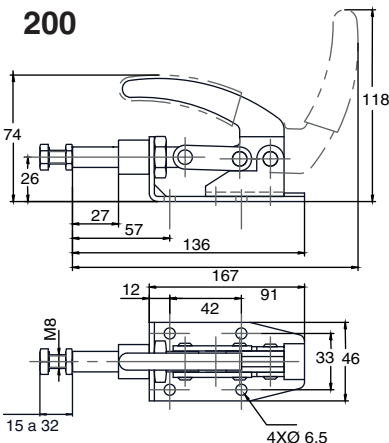

Tutte le immagini sono inserite a scopo illustrativo. I prodotti possono subire modifiche.

Prezzi in EURO - IVA esclusa